



MDA
DESIGNS
BRINGING DESIGN TO LIFE

DESCRIPTION:

CURVE 1000 MEDIA UNIT

1.0 hr

APPROXIMATE ASSEMBLY TIME

1 PERSON ASSEMBLY



FLOOR AREA
2.0M X2.0M

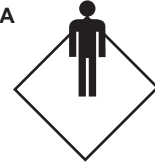

REQUIRED ASSEMBLY SPACE

ASSEMBLED DIMENSIONS

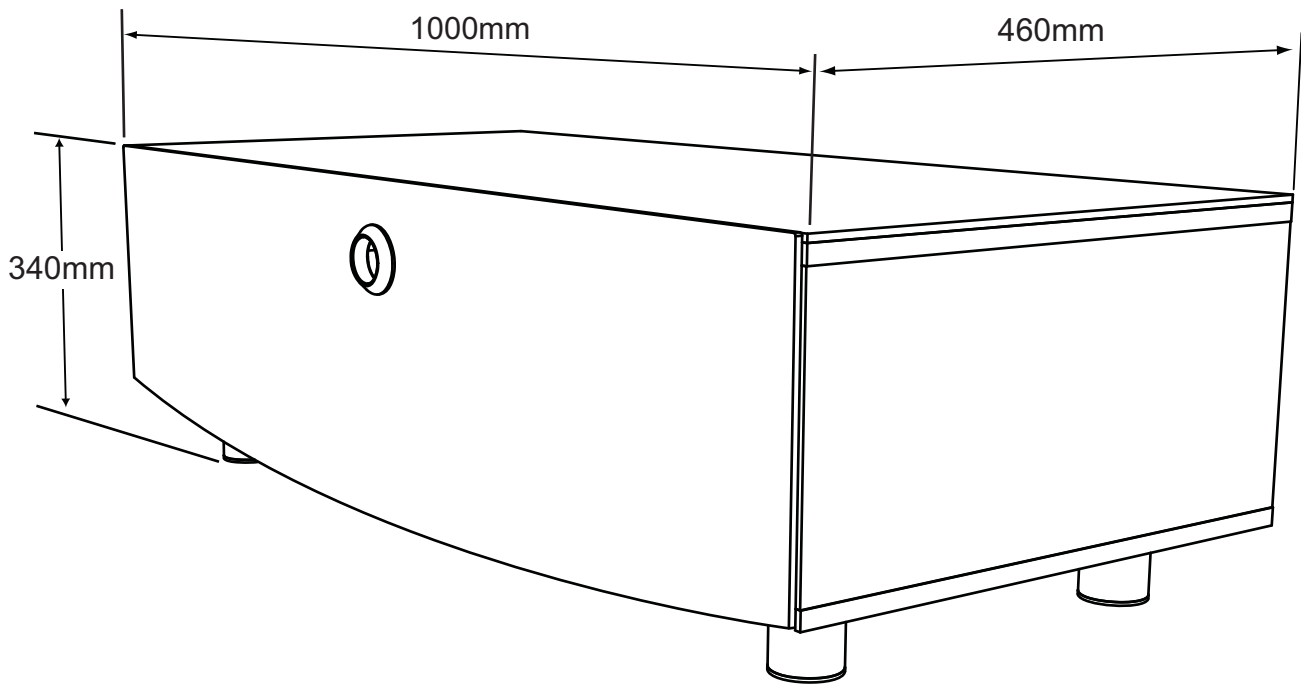



CURVE

DESCRIPTION:

CURVE 1000 MEDIA UNIT

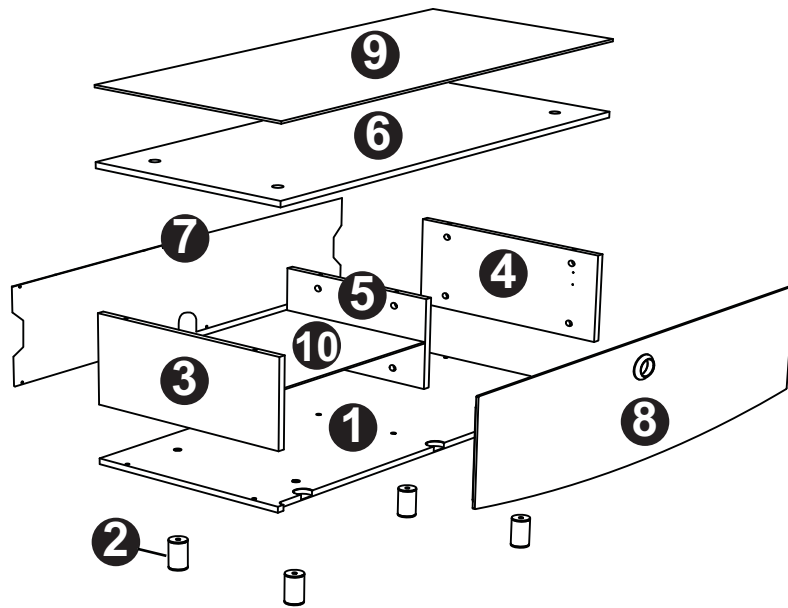
PARTS LIST

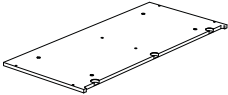

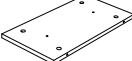
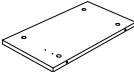
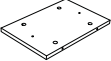
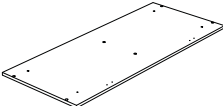
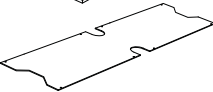
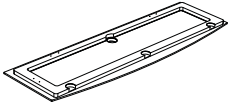
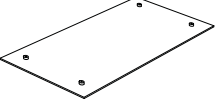
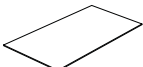
no.		PART LIST	QTY
(1)		BASE PANEL	1
(2)		FOOT	4
(3)		LEFT HAND SIDE PANEL	1
(4)		RIGHT HAND SIDE PANEL	1
(5)		CENTRE PANEL	1
(6)		TOP PANEL	1
(7)		REAR COVER PANEL	1
(8)		FRONT DOOR ASSEMBLY	1
(9)		GLASS TOP PANEL	1
(10)		GLASS SHELF	1

CURVE



DESCRIPTION:

CURVE 1000 MEDIA UNIT

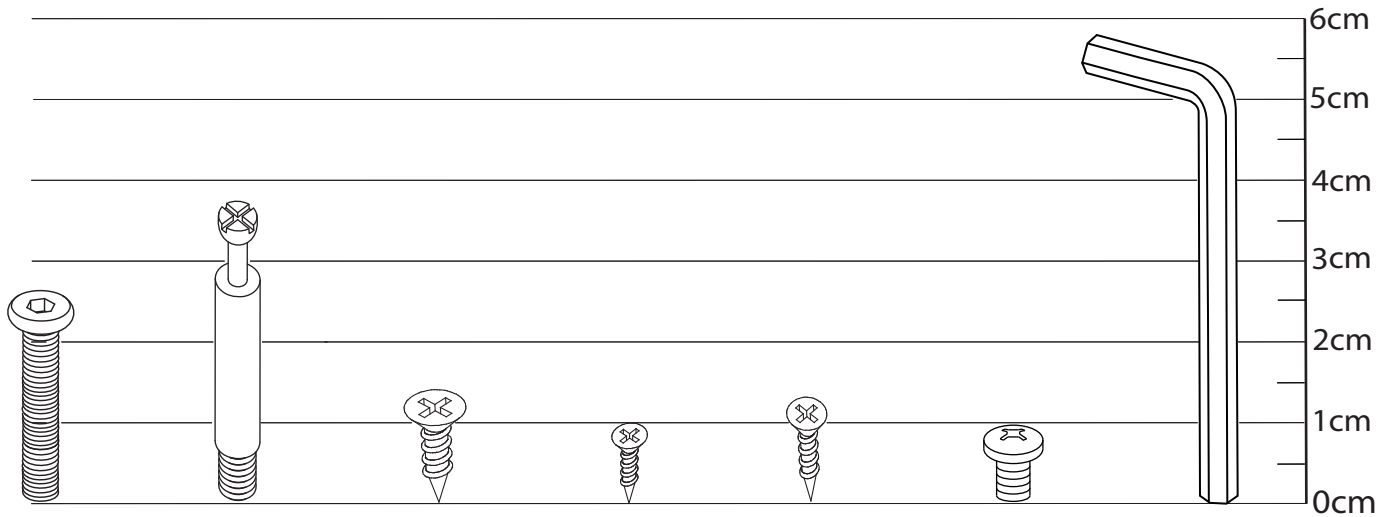
HARDWARE LIST

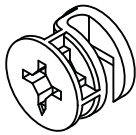
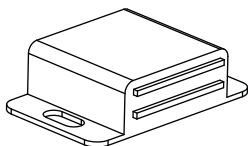
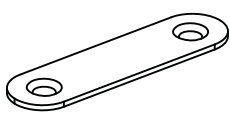

- | | | | | | | |
|--|--|---|---|---|---|--|
| 4x
M6 x 30mm
A
BOLT | 12x
M6 x 38mm
B
CAM PIN | 8x
M3.5 x 14mm
C
SCREW | 4x
M3 x 10mm
D
SCREW | 8x
M3 x 14mm
E
SCREW | 3x
M4 x 10mm
F
SCREW | 1x
M4 x 65mm
G
4mm ALLEN
KEY |
|--|--|---|---|---|---|--|

- | | | | |
|--|--|---|--|
| 
12x
12 x 10mm
H
CAM LOCK | 
2x
25 x 40mm
I
MAG CATCH | 
2x
15 x 40mm
J
MAG CATCH PLATE | 
4x
15 x 40mm
K
SHELF PEG |
|--|--|---|--|

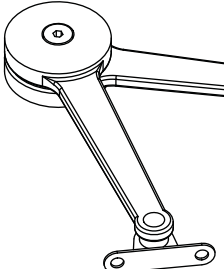
- 
- 1x**
120 x 40mm
L
DOOR STAY

Top Tips before you start!

1. Please check that all parts are present before you start the assembly of your furniture.
2. For ease and speed of assembly, we recommend that before you commence each step of the assembly, that you identify all the parts required for that step.
3. For larger items, please ensure that you have sufficient space and people (as indicated on page 1) to assemble your product safely
4. We recommend that, where possible, all items are assembled near to the area in which they will be placed in use, to avoid moving the product unnecessarily once assembled.
5. For the protection of your furniture, particularly items of high gloss finish, we recommend that the product is placed on a protected surface during assembly to prevent any damage.
6. During assembly please take care not to over-tighten any fittings, as this may damage the product.

Care and Maintenance of your Furniture

- Please periodically check all fittings and re-tighten as necessary.
- Please do not sit or stand on this item.
- Never allow any kind of liquid to remain on your furniture, Absorption can cause wood to warp or finishes to de-laminate
- Please do not drag and pull your furniture.
- If the glass is chipped or broken, stop using the product and consult the manufacturer or supplier.
- Please do not place very hot or very cold items on the glass surface, unless adequately thick table mats are used to prevent such items from coming into contact with the glass.
- Please do not use the glass as a chopping surface. Do not strike the glass with hard or pointed items.
- When cleaning glass panels use a damp cloth or leather with washing up liquid or soft soap if necessary, do not use washing powders or any other substances containing abrasives since these substances scratch glass.
- The glass used in this product is toughened and complies with BS EN 12150-1:2000, clauses 8.3 & 8.4

CURVE

DESCRIPTION:
CURVE 1000 MEDIA UNIT

STEP 1

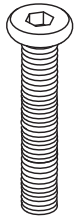
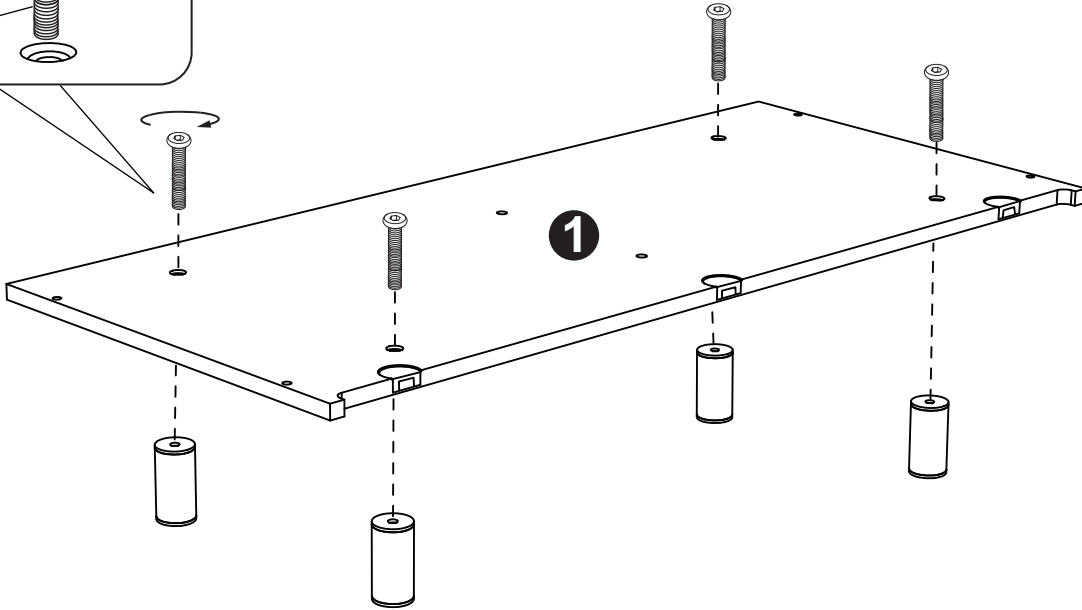
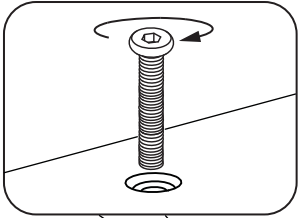

4x
A

STEP 2

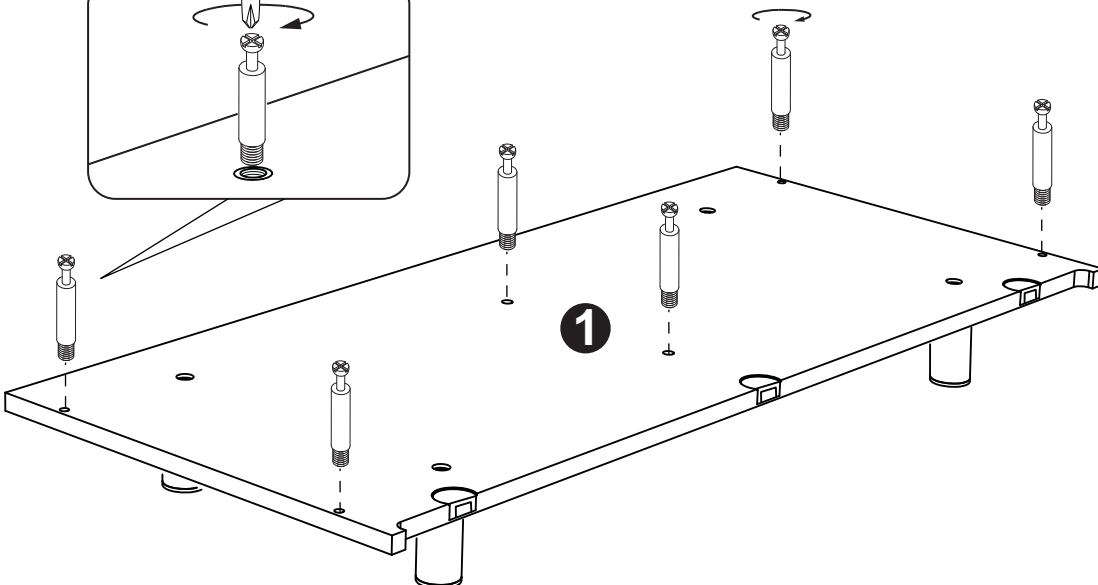
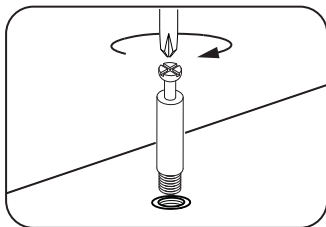

6x
B

CURVE

DESCRIPTION:

CURVE 1000 MEDIA UNIT

STEP 3

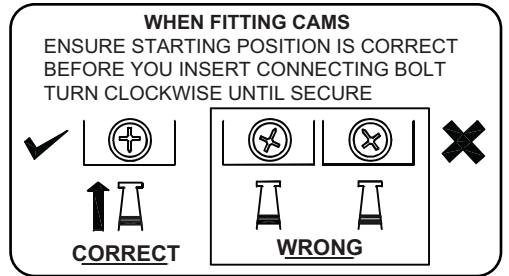
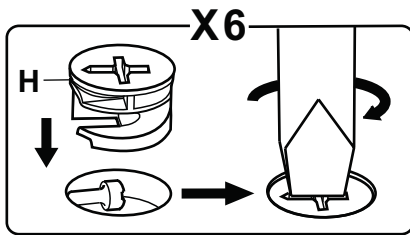
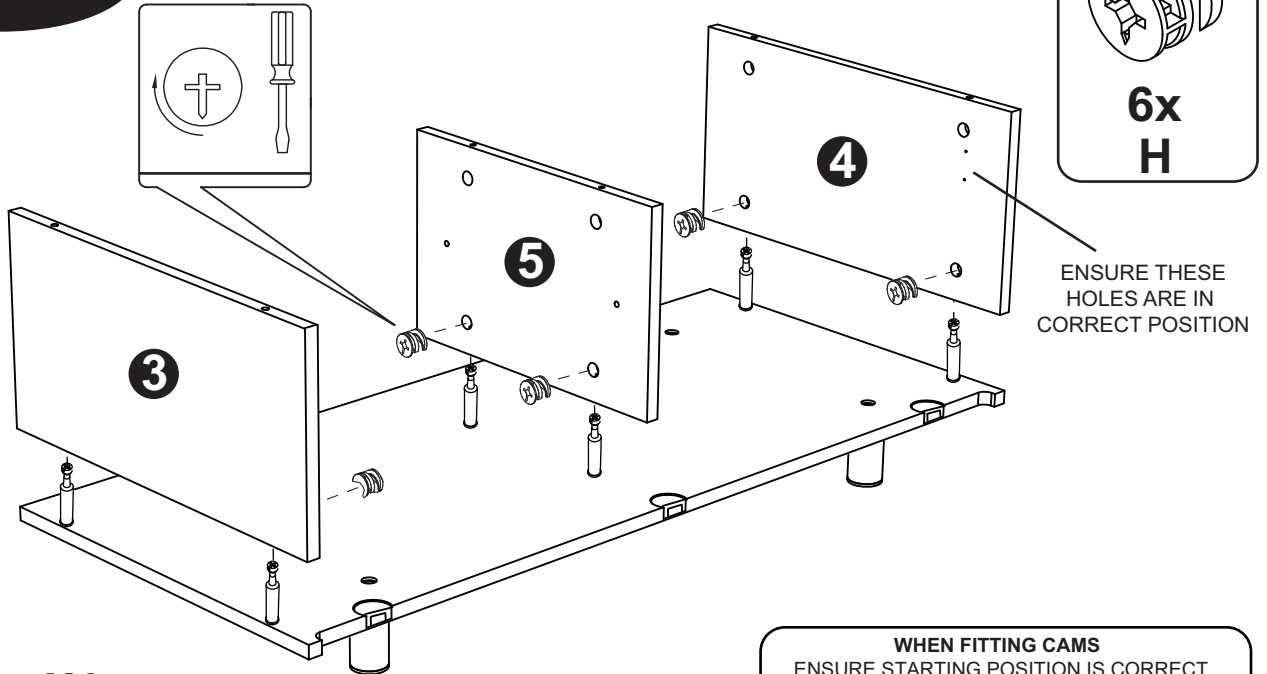

STEP 4

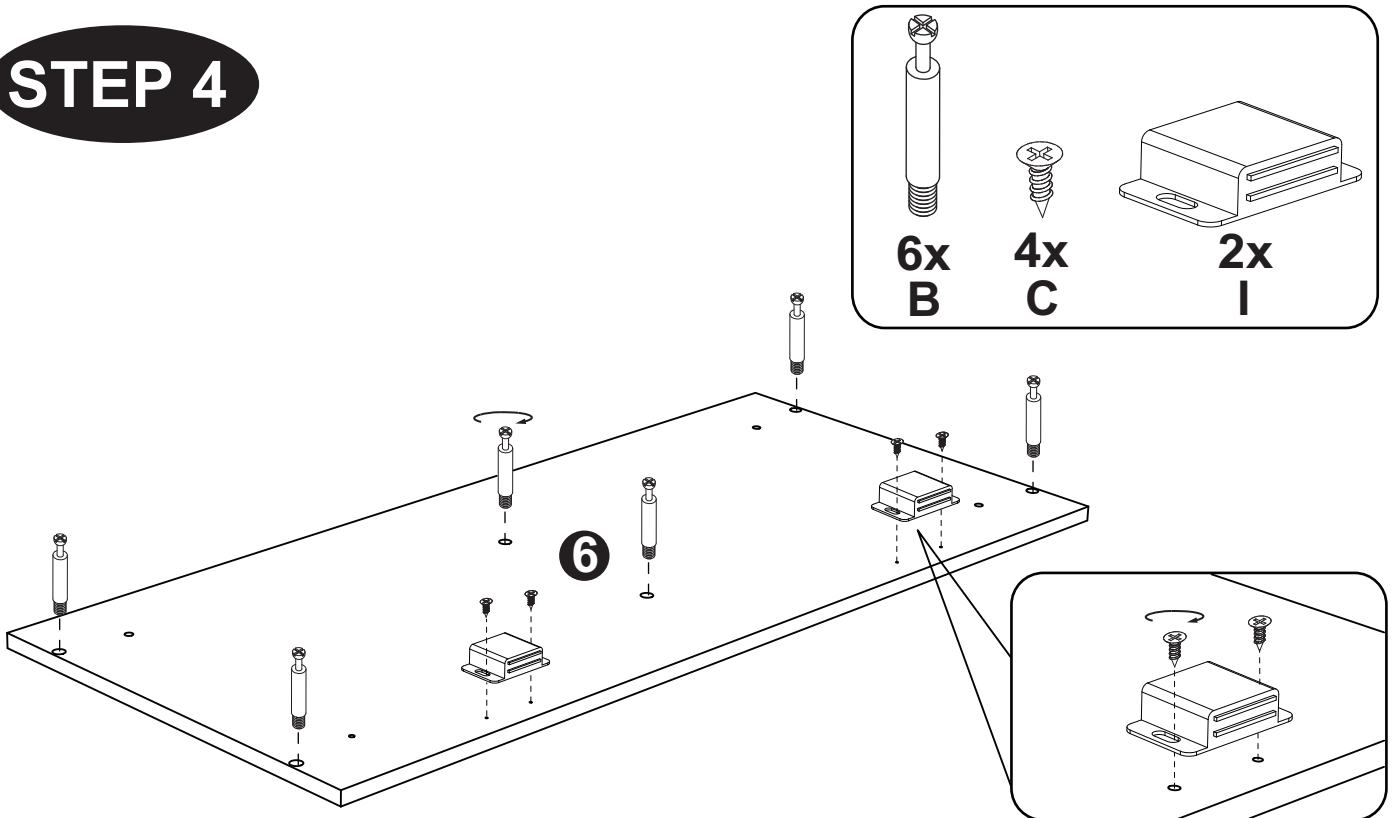

CURVE

DESCRIPTION:

CURVE 1000 MEDIA UNIT

STEP 5

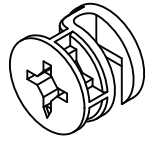
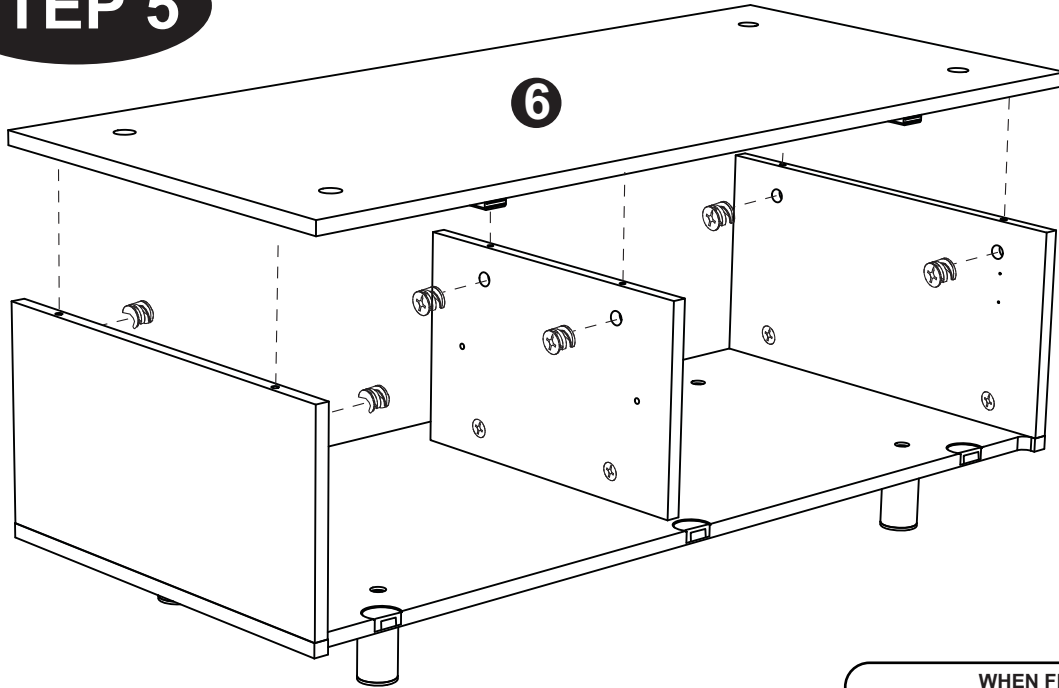

6x
H

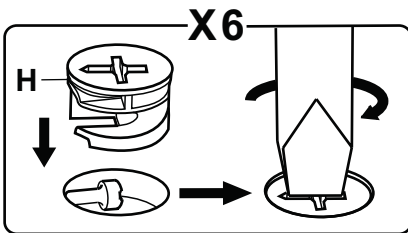

WHEN FITTING CAMS
ENSURE STARTING POSITION IS CORRECT
BEFORE YOU INSERT CONNECTING BOLT
TURN CLOCKWISE UNTIL SECURE

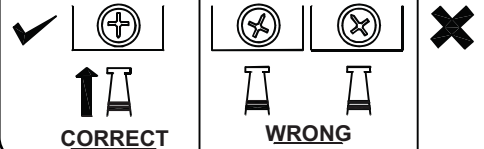

STEP 6

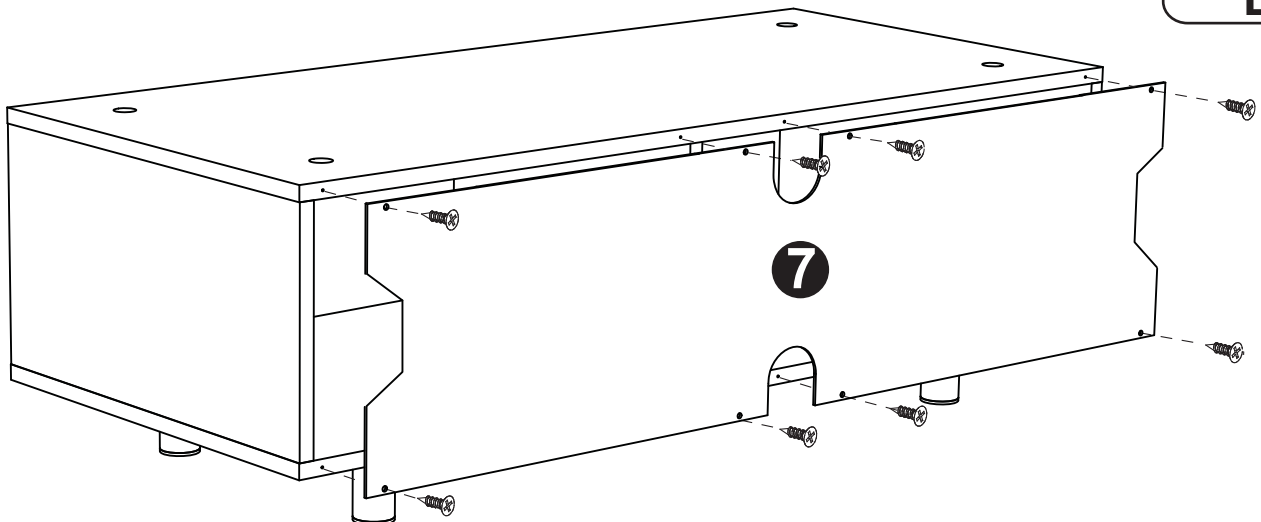

8x
E

CURVE

DESCRIPTION:

CURVE 1000 MEDIA UNIT

STEP 7



4x
K



2x
C

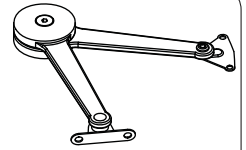

1x
L

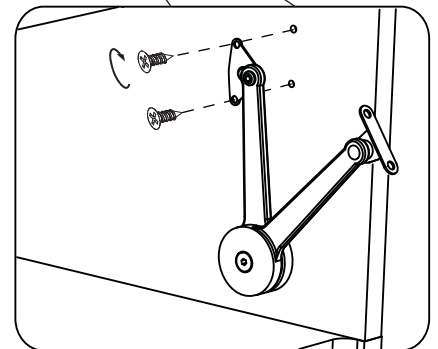
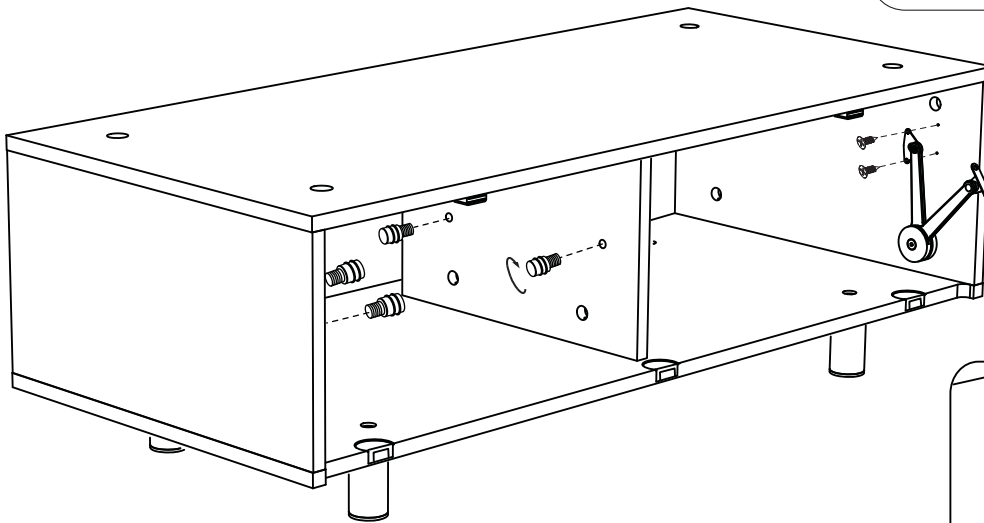

STEP 8



4x
D

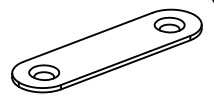

2x
J

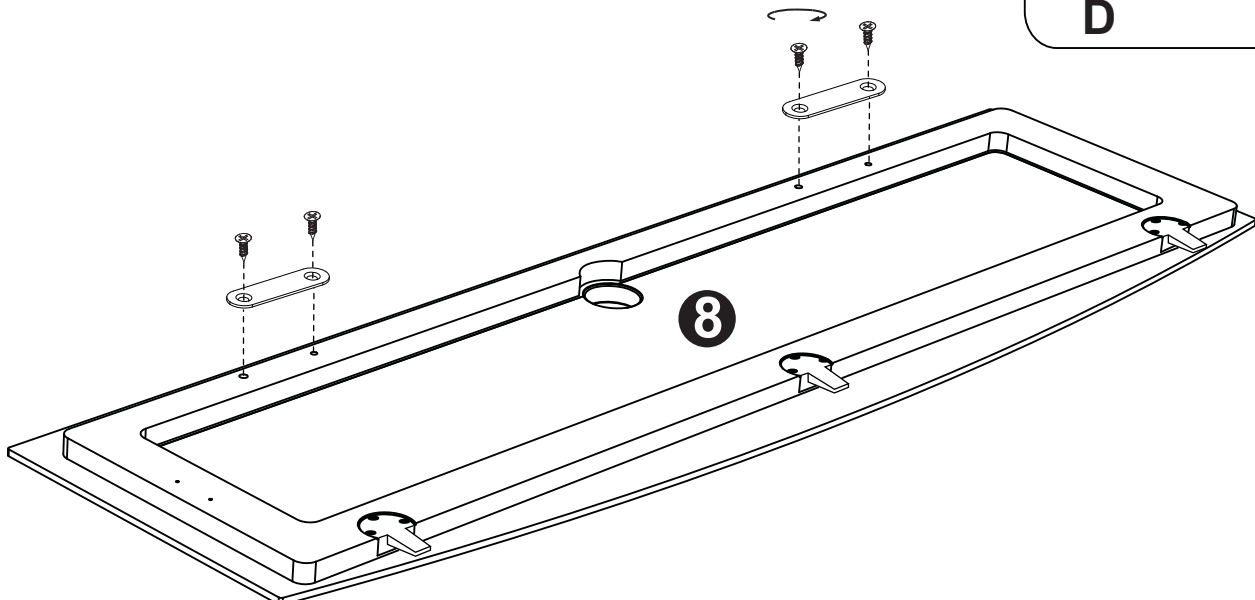

CURVE

DESCRIPTION:

CURVE 1000 MEDIA UNIT

STEP 9

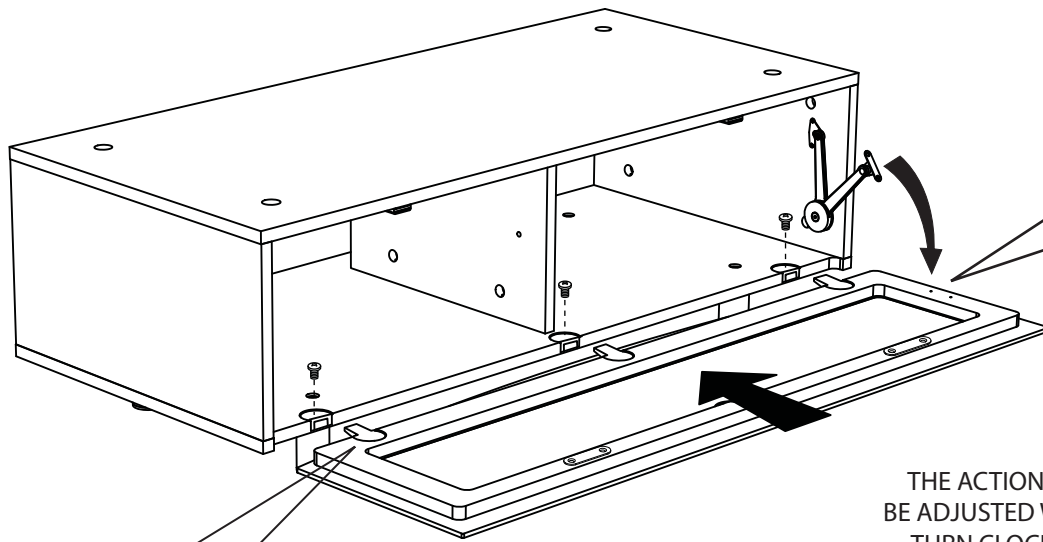

2x
C



3x
F

2x
C

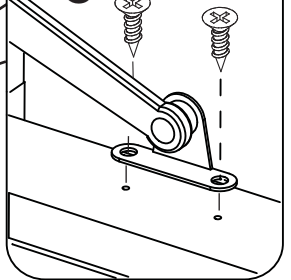

THE ACTION OF THE DOOR DAMPER CAN BE ADJUSTED WITH THE ALLEN KEY SUPPLIED. TURN CLOCKWISE TO INCREASE TENSION

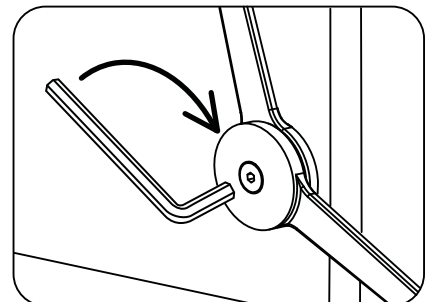
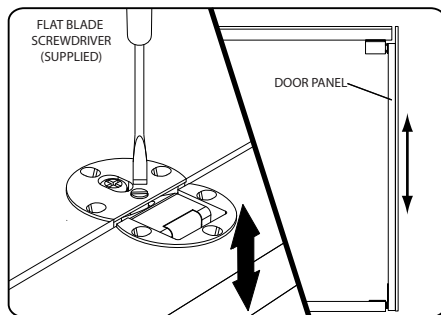
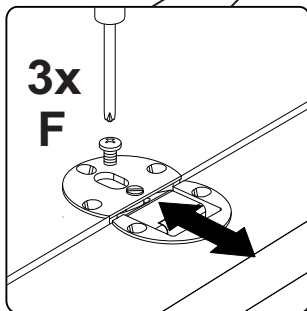

STEP 10

